

# BOROUGH OF PENNSBURG ROAD OPENING PERMITS

76 West 6<sup>th</sup> Street, Pennsburg, PA 18073 Office:215-679-4546 Fax: 215-679-5140

The following fees are applied to the administrative costs incurred in reviewing the applications and plan(s) and issuing and processing the permit, (including the preliminary review of the site location identified in the application) **whether or not a permit is issued** and processed.

All permits will have an additional \$5.00 administrative fee.

<b>Construction Entrances</b>	
Non-refundable Application Fee	\$50.00
Permit	50.00
Utilities (i.e., storm, gas, sewer, etc.)	75.00
<b>Driveways</b> (for driveways onto Borough Dedicated Public Roadways only)	
Minimum use (e.g., single –family dwellings, apartments with five or fewer units, not more than 25 cars)	25.00
Low volume (e.g., office buildings, car washes, more than 25 but less than 750)	70.00
Medium volume (e.g., motels, fast food restaurants, service stations, small shopping plazas, more that 750 but less than 1,500)	95.00
High volume (e.g., large shopping centers, multi-building apartment or office complexes, more than 1,500)	120.00
Other (e.g., bank removal, sidewalk and curb)	25.00
Permit Extension (each six-month extension OR each change)	20.00
Emergency Permit Card	15.00
<b>Surface Openings-</b> Calculated on the total linear feet of the opening being permitted within different areas of the right-of-way	
a) Total linear feet of opening each (100-foot increments or fractions thereof)	
Opening in pavement	50.00
Opening in shoulder	40.00
Opening outside pavement and shoulder	30.00
b) If a longitudinal opening simultaneously occupies two or more high-way areas identified in subparagraph (a), only the higher fee will be charged. Linear distances shall be measured to the nearest foot.	
<b>Surface Openings – Of less than 36 Square Feet</b> (e.g., service connections performed independently of underground facility installation, pipe line repairs- each opening)	
Opening in pavement	50.00
Opening in shoulder	25.00
Opening outside pavement and shoulder	
<b>Above-ground Facilities</b> (e.g., poles, guys and/or anchors if installed independently of poles)	
Up to 10 physically connected above-ground facilities (each continuous group)	35.00
Additional above-ground physically connected facilities (each pole with appurtenances)	7.00

**BOROUGH OF PENNSBURG  
DRIVEWAY PERMIT APPLICATION**

76 West 6<sup>th</sup> Street, Pennsburg, PA 18073 Office:215-679-4546 Fax: 215-679-5140

Date of Application: \_\_\_\_\_ PERMIT FEES: \_\_\_\_\_

Name of Applicant: \_\_\_\_\_

Address: \_\_\_\_\_

Phone: \_\_\_\_\_ Fax: \_\_\_\_\_

Owner (if other than applicant): \_\_\_\_\_

Address: \_\_\_\_\_

Phone: \_\_\_\_\_ Fax: \_\_\_\_\_

Name of Contractor or Builder: \_\_\_\_\_

Address: \_\_\_\_\_

Phone: \_\_\_\_\_ Fax: \_\_\_\_\_

Property Address of Site: \_\_\_\_\_

Location of Driveway: \_\_\_\_\_

\_\_\_\_\_

\_\_\_\_\_

Statement of Materials and Construction to be used: \_\_\_\_\_

\_\_\_\_\_

\_\_\_\_\_

I hereby certify that the information hereon and herewith is true and correct to the best of my knowledge, and furthermore the property owner has authorized the work.

Applicant's Signature: \_\_\_\_\_ Date: \_\_\_\_\_

\_\_\_\_\_

Permit No. \_\_\_\_\_ Date Issued: \_\_\_\_\_

Approved by Inspector: \_\_\_\_\_ Date: \_\_\_\_\_

Signature

Amount Received: \_\_\_\_\_ Check: \_\_\_\_\_ Cash: \_\_\_\_\_

# DRIVEWAY SKETCH

Owner: \_\_\_\_\_ Applicant Name: \_\_\_\_\_  
 Property Address: \_\_\_\_\_ Applicant Address: \_\_\_\_\_  
 Phone #: \_\_\_\_\_ Phone #: \_\_\_\_\_  
 Cell Phone #: \_\_\_\_\_ Cell Phone #: \_\_\_\_\_

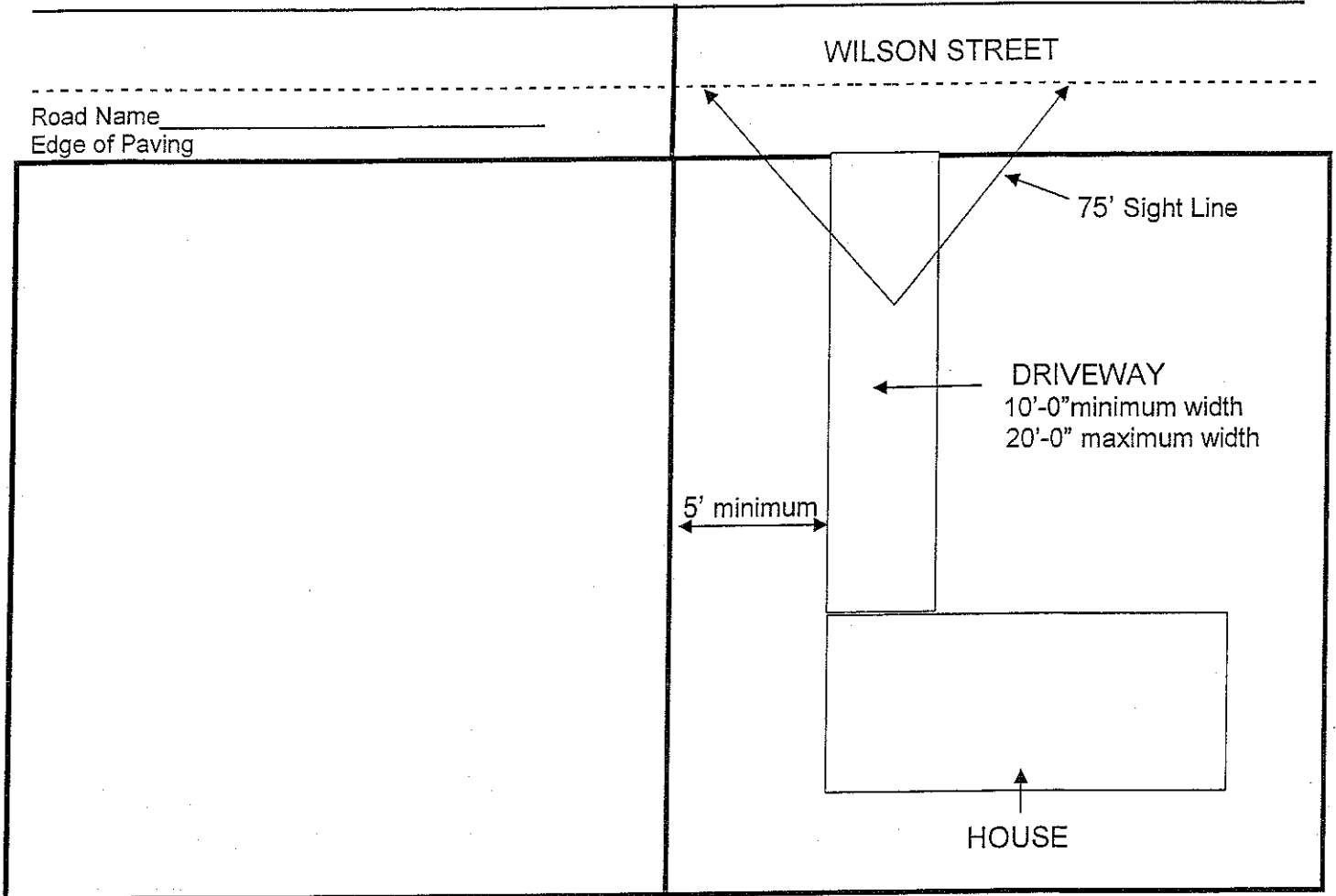

**SKETCH**

**EXAMPLE**

Corner Lot Driveway  
 must be 100 feet from  
 intersection

**Notes:**

1. Provide sketch showing information in example above.
2. Minimum driveway width 10' - 0".
3. 5' minimum distance from property line
4. If pipe involved for roadway drainage, show:
  - A. Length - minimum 20 feet
  - B. Location- minimum 2 feet from edge of paving
  - C. Diameter - minimum 15 inches
  - D. Pipe Coverage - minimum 6 inches
  - E. No corrugated metal pipe permitted
5. Must have a 75' clear site triangle

## APPLICATION FOR BOROUGH ROAD OCCUPANCY PERMIT

Borough of Pennsburg  
76 West 6<sup>th</sup> Street  
Pennsburg, PA 18073

Permit # \_\_\_\_\_  
Date: \_\_\_\_\_  
Issuing Permit Fee \$ \_\_\_\_\_  
Borough Inspection Fee \$ \_\_\_\_\_  
TOTAL \$ \_\_\_\_\_

Road name where work is to be done: \_\_\_\_\_

Name: \_\_\_\_\_ Phone: \_\_\_\_\_

Address: \_\_\_\_\_

For permission to: \_\_\_\_\_

Description and purpose of work: \_\_\_\_\_

\_\_\_\_\_  
\_\_\_\_\_  
\_\_\_\_\_

Under and subject to all the conditions, restrictions, and regulations prescribed by the Borough and on the general provisions and specifications a true copy whereof is attached and made a part hereof, with the same force and effect as if written or printed herein and under and subject to the special conditions, restrictions, and regulations hereinafter set forth.

### DATA APPLICABLE TO THIS APPLICATION

**GENERAL.** Approximate date when work will be started: \_\_\_\_\_. Approximate date when work will be completed: \_\_\_\_\_. The road surface is improved to a width of \_\_\_\_\_ feet. Distance from center of line to roadway to gutter or ditch: \_\_\_\_\_ feet. Distance from centerline of road to Right-Of-Way line: \_\_\_\_\_ feet.

**POLES AND TOWER.** Number of poles to be erected: \_\_\_\_\_. Nearest distance from center of road to structure: \_\_\_\_\_ feet. Distance of proposed work along the road \_\_\_\_\_ feet.

**PIPE LINE AND CONDUITS.** The improved surface of the road (will) (will not) be opened. Approximate area of openings in improved surface \_\_\_\_\_ sq. yds. Approximate area of openings on unimproved part \_\_\_\_\_ sq. yds. Length of trench along the road: \_\_\_\_\_ feet. Depth of trench below surface: \_\_\_\_\_ inches.

### TO BE COMPLETED BY BOROUGH

Schedule Item Number						
Unit Fee						
Number of Units						
Total Fee						

The applicant is (an individual) (a partnership) (a corporation incorporated under the laws of \_\_\_\_\_)

(Corporate Seal)

Name of Applicant \_\_\_\_\_

By: \_\_\_\_\_  
(EXECUTIVE OFFICER OR AUTHORIZED REPRESENTATIVE)

### GENERAL INSTRUCTIONS

Any work performed within the right-of-way of a Borough road requires submission of three (3) copies of this form along with three (3) copies of a sketch showing the location and details of the proposed work. Any work performed on a Borough road over, under, or within the limits of a limited access state highway, requires a state permit. The prescribed permit fee shall accompany the application and sketch. Schedules of fees are furnished on request.

**FEE SHALL BE PAID BY CHECK OR MONEY ORDER PAYABLE TO BOROUGH OF PENNSBURG**

## BOROUGH ROAD OCCUPANCY PERMIT

All work under this permit to be completed on or before: \_\_\_\_\_  
*\*Permit void after this date. Immediately upon completion of the work, permittee should notify the Borough.*

Date Issued \_\_\_\_\_  
Total Fees \_\_\_\_\_  
Permit # \_\_\_\_\_

Permission is hereby granted to:

PERMITTEE	Route No., Road or Street where work is to be done
ADDRESS	Borough
CITY/State	County
ZIP CODE	

Under and subject to all the conditions, restrictions, and regulations prescribed by the Borough and on the general provisions and specifications a true copy whereof is attached and made a part hereof, with the same force and effect as if written or printed herein and under and subject to the special conditions, restrictions, and regulations hereinafter set forth.

(DESCRIPTION AND PURPOSE OF WORK)

---

---

---

---

---

The Borough of Pennsburg may, at any time revoke and annul this permit for non-performance of, or non-compliance of the conditions, restrictions, and regulations hereof.

Approved \_\_\_\_\_  
Day Month Year

\_\_\_\_\_  
Borough Signature or Seal

### IMPORTANT

The terms and conditions embodied in this permit require the permittee to complete this work by the date specified in the permit. Where permittee fails to comply with the conditions as to completion of work by the time specified, the following rules will govern:

- (a) **Failure to start work by date specified for completion.** Permit will be cancelled unless permittee desires an extension of time, in which case a supplemental permit may be issued.
- (b) **Work started and not completed by specified date.** Permittee will notify Borough prior to expiration of allotted time, of inability to complete the work on or before the date specified and request an extension of time. Such request shall be accompanied by the prescribed fee.
- (c) **Permittee not desirous of carrying out proposed work on account of change in conditions affecting it.** Permittee will notify the Borough prior to the date specified for completion that work will not be carried forward, returning the permit with such notice. The fee for inspection of the work will be refunded by the Borough provided that they have been notified of cancellation prior to expiration date.

The fees to be paid under the conditions in (a), (b), and (c) apply only to permits for which fees are collected in accordance with the fixed schedule.  
All notices relative to time extensions or cancellations shall be forwarded to the Borough which issued original permit.

---

Amount Received: \_\_\_\_\_ Check: \_\_\_\_\_ Cash: \_\_\_\_\_

# FLEXIBLE PAVEMENT RESTORATION

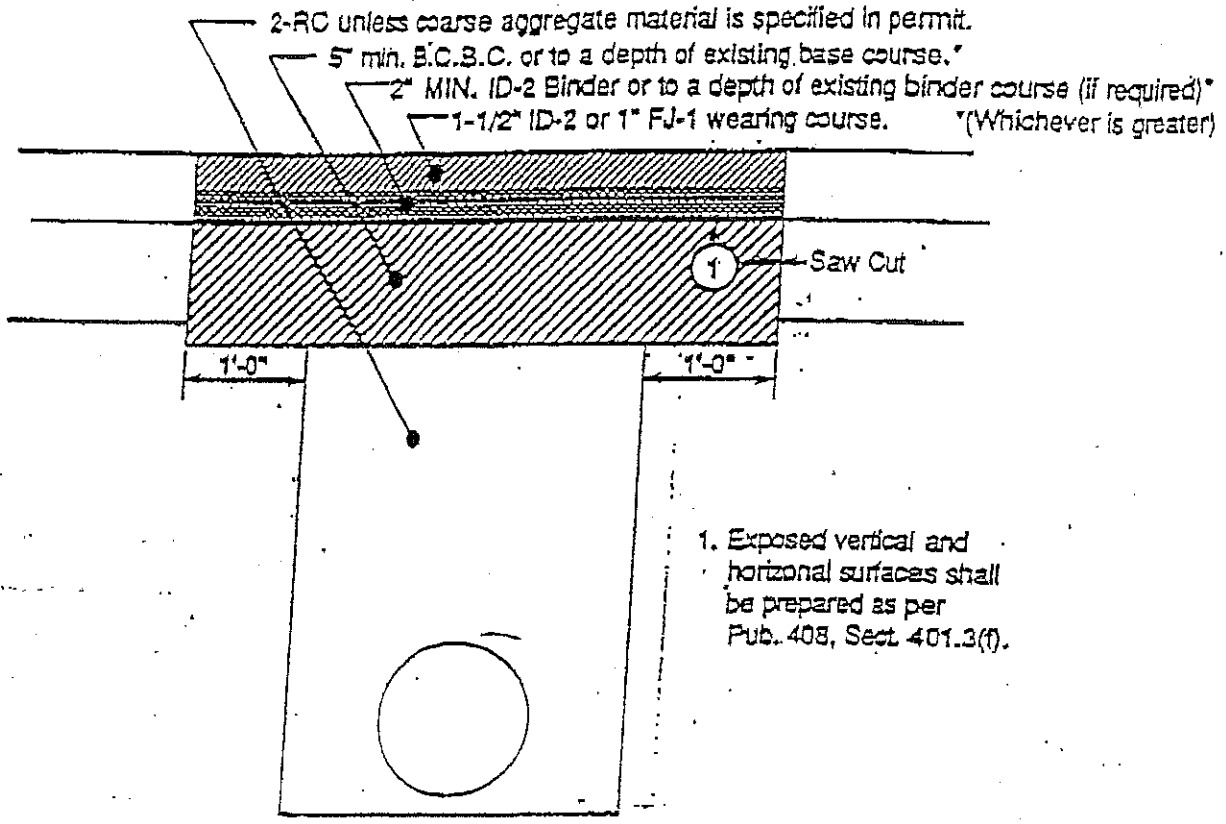

FIGURE 7-4

# RIGID PAVEMENT RESTORATION

